

Lien\_2019\_J.\_Phys.\_Conf.\_Ser.\_  
1179\_012085.pdf  
*by*

---

**Submission date:** 02-Nov-2021 12:56AM (UTC-0400)

**Submission ID:** 1690764088

**File name:** Lien\_2019\_J.\_Phys.\_Conf.\_Ser.\_1179\_012085.pdf (754.8K)

**Word count:** 2800

**Character count:** 13747

PAPER • OPEN ACCESS

## A Hyperchaotic System with Three Quadratic Nonlinearities, its Dynamical Analysis and Circuit Realization

To cite this article: C-H Lien *et al* 2019 *J. Phys.: Conf. Ser.* **1179** 012085

View the [article online](#) for updates and enhancements.

### You may also like

- [A New 4-D Hyperchaotic System with Four-Scroll Hidden Attractor, Its Properties and Bifurcation Analysis](#)  
L G Dolvis, S Vaidyanathan, K Jacques et al.
- [A new hyperchaotic complex system and its synchronization realization](#)  
Zhengfeng Li, Fangfang Zhang, Xue Zhang et al.
- [Modified projective synchronization of a new four-dimensional chaotic system using active control](#)  
Y Tang, Q Miao, S Lu et al.



The Electrochemical Society  
Advancing solid state & electrochemical science & technology

### 241st ECS Meeting

May 29 – June 2, 2022 Vancouver • BC • Canada  
Abstract submission deadline: Dec 3, 2021

Connect. Engage. Champion. Empower. Accelerate.  
We move science forward



Submit your abstract



## A Hyperchaotic System with Three Quadratic Nonlinearities, its Dynamical Analysis and Circuit Realization

C-H Lien<sup>1,\*</sup>, S Vaidyanathan<sup>2</sup>, S Zhang<sup>3</sup>, A Sambas<sup>4</sup>, Mujiarto<sup>4</sup> and Subiyanto<sup>5</sup>

<sup>1</sup> Department of Marine Engineering, National Kaohsiung University of Science and Technology, Kaohsiung, Taiwan

<sup>2</sup> Research and Development Centre, Vel Tech University, Avadi, Chennai, India

<sup>3</sup> School of Physics and Optoelectric Engineering, Xiangtan University, Hunan, China

<sup>4</sup> Department of Mechanical Engineering, Universitas Muhammadiyah Tasikmalaya, Indonesia

<sup>5</sup> Department of Marine Science, Faculty of Fishery and Marine Science, Universitas Padjadjaran, Indonesia

\*chlien@mail.nkmu.edu.tw

**Abstract.** A new four-dimensional hyperchaotic system with three quadratic nonlinearities is proposed in this paper. The dynamical properties of the new hyperchaotic system are explored in terms of phase portraits, Lyapunov exponents, Kaplan-Yorke dimension, dissipativity, etc. Also, a detailed dynamical analysis of the new hyperchaotic system has been carried out with bifurcation diagram and Lyapunov exponents. As an engineering application, an electronic circuit realization of the new hyperchaotic system is designed via MultiSIM to confirm the feasibility of the theoretical hyperchaotic model.

### 1. Introduction

Chaotic systems are nonlinear dynamical systems that are highly sensitive to initial conditions [1-2]. Chaotic systems that arise in modelling have many applications in science and engineering such as weather systems [3], ecology [4], neurons [5], biology [6], cellular neural networks [7], chemical reactors [8], oscillators [9], robotics [10], encryption [11-12], finance systems [13], circuits [14-15], secure communication [16], etc.

A hyperchaotic system is a chaotic system having two or more positive Lyapunov exponents [1-2]. The first hyperchaotic system was reported by Rössler [17]. Other famous hyperchaotic systems are hyperchaotic Lorenz system [18], hyperchaotic Chen system [19], hyperchaotic Lü system [20], hyperchaotic Rabinovich system [21], hyperchaotic Vaidyanathan systems [22], etc.

In this research paper, we report the finding of a new hyperchaotic system with three quadratic nonlinearities. We describe the phase plots of the new hyperchaotic system and do a rigorous dynamic analysis by finding equilibrium points and their stability, bifurcation diagrams, Lyapunov exponents, etc. Bifurcation analysis is very useful to understand the special properties of chaotic and hyperchaotic systems [23-26].

Section 2 describes the new hyperchaotic system, its phase plots and Lyapunov exponents. Section 3 describes the dynamic analysis of the new hyperchaotic system. Furthermore, an electronic circuit



Content from this work may be used under the terms of the [Creative Commons Attribution 3.0 licence](https://creativecommons.org/licenses/by/3.0/). Any further distribution of this work must maintain attribution to the author(s) and the title of the work, journal citation and DOI.

Published under licence by IOP Publishing Ltd

realization of the new chaotic system is presented in detail in Section 4. The circuit experimental results of the new hyperjerk system in Section 4 agreement with its numerical simulations via MATLAB obtained in Section 2. Section 5 draws the main conclusions.

## 2. A new hyperchaotic system with three quadratic nonlinearities

In this work, we report a new 4-D system given by the dynamics

$$\begin{cases} \dot{x}_1 = a(x_2 - x_1) + x_2 x_3 \\ \dot{x}_2 = b x_2 - x_1 x_3 + x_4 \\ \dot{x}_3 = -c x_3 + x_1 x_2 \\ \dot{x}_4 = -d(x_1 + x_2) \end{cases} \quad (1)$$

where  $x_1, x_2, x_3, x_4$  are state variables and  $a, b, c, d$  are positive constants.

In this paper, we show that the 4-D system (1) is *hyperchaotic* for the parameter values

$$a = 30, \quad b = 15, \quad c = 3, \quad d = 2 \quad (2)$$

For numerical simulations and the calculation of Lyapunov exponents, we take the initial values of the new system (1) as  $X(0) = (0.1, 0.1, 0.1, 0.1)$ . Using MATLAB, the Lyapunov exponents of the system (1) for the parameter values (2) are computed as follows:

$$LE_1 = 1.3700, \quad LE_2 = 0.1450, \quad LE_3 = 0, \quad LE_4 = -19.5150 \quad (3)$$

From the LE spectrum given in (3), it is immediate that the new system (1) is hyperchaotic for the parameter values  $(a, b, c, d) = (30, 15, 3, 2)$ , since there are two positive Lyapunov exponents in (3). Since the sum of the Lyapunov exponents in (3) is negative, we also conclude that the 4-D hyperchaotic system (1) is dissipative. This confirms the existence of a strange hyperchaotic attractor.

The Kaplan-Yorke dimension of the system (1) is calculated as

$$D_{KY} = 3 + \frac{LE_1 + LE_2 + LE_3}{|LE_4|} = 3.0776, \quad (4)$$

which gives a measure of the complexity of the new hyperchaotic system (1).

The system (1) is invariant under the change of coordinates given by

$$(x_1, x_2, x_3, x_4) \mapsto (-x_1, -x_2, x_3, -x_4) \quad (5)$$

This shows that the system (1) has rotation symmetry about the  $x_3$ -axis. As a consequence, every non-trivial trajectory of the 4-D hyperchaotic system (1) must have a twin trajectory.

The equilibrium points of the system (1) are found by solving the system of equations:

$$\begin{cases} a(x_2 - x_1) + x_2 x_3 = 0 \\ b x_2 - x_1 x_3 + x_4 = 0 \\ -c x_3 + x_1 x_2 = 0 \\ -d(x_1 + x_2) = 0 \end{cases} \quad (6)$$

For solving the nonlinear system (6), we take the parameter values as in (2).

From the last equation in (6),  $x_1 = -x_2$ .

Thus, the variable  $x_2$  can be eliminated and we obtain a nonlinear system of three equations as follows:

$$-x_1(x_3 + 60) = 0 \quad (7a)$$

$$x_4 = x_1(x_3 + 15) \quad (7b)$$

$$x_1^2 = -3x_3 \quad (7c)$$

We have two cases to consider in solving the nonlinear system (7).

Case (A):  $x_1 = 0$ .

In this case,  $x_2 = -x_1 = 0$ . From equations (7a) and (7c), it is clear that  $x_3 = x_4 = 0$ .

Thus, we obtain one equilibrium point of the hyperchaotic system (1) as

$$E_0 = \begin{bmatrix} 0 \\ 0 \\ 0 \\ 0 \end{bmatrix} \tag{8}$$

Case (B):  $x_1 \neq 0$ .

In this case, from (7a),  $x_3 = -60$ . Eq. (7c) gives us  $x_1^2 = 180$  and so  $x_1 = \pm\sqrt{180}$ .

Since  $x_2 = -x_1$ , it follows that  $x_2 = \mp\sqrt{180}$ . From Eq. (7c), we find that  $x_4 = \pm 603.7384$ .

Thus, the hyperchaotic system (1) has two more equilibrium points given by

$$E_1 = \begin{bmatrix} \sqrt{180} \\ -\sqrt{180} \\ -60 \\ 603.7384 \end{bmatrix} \text{ and } E_2 = \begin{bmatrix} -\sqrt{180} \\ \sqrt{180} \\ -60 \\ -603.7384 \end{bmatrix} \tag{9}$$

The Jacobian matrix of the hyperchaotic system (1) at any point  $x$  in

$$J(x) = \begin{bmatrix} -a & a+x_3 & x_2 & 0 \\ -x_3 & b & -x_1 & 1 \\ x_2 & x_1 & -c & 0 \\ -d & -d & 0 & 0 \end{bmatrix} \tag{10}$$

We assume that the parameter values are as in the hyperchaotic case (2).

The Jacobian matrix  $J_0 = J(E_0)$  has the eigenvalues

$$\lambda_1 = -3, \lambda_2 = -30.0443, \lambda_3 = 0.2703, \lambda_4 = 14.7739 \tag{11}$$

This shows that the equilibrium  $E_0$  is a saddle-point and unstable.

The Jacobian matrix  $J_1 = J(E_1)$  has the eigenvalues

$$\lambda_1 = 0.0254, \lambda_2 = -19.8140, \lambda_{3,4} = 0.8943 \pm 37.8431i$$

This shows that the equilibrium  $E_1$  is a saddle-focus and unstable.

Since  $J_2 = J(E_2)$  has the same set of eigenvalues as  $J_1 = J(E_1)$ , we conclude that the equilibrium  $E_2$  is also a saddle-focus and unstable.

Figures 1-4 show the 2-D projections of the new hyperchaotic system (1) in  $(x_1, x_2)$ ,  $(x_2, x_3)$ ,  $(x_3, x_4)$  and  $(x_1, x_4)$  coordinate planes, respectively.

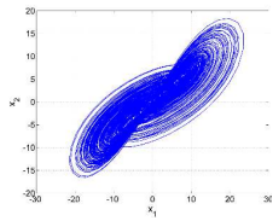

**Figure 1.** 2-D plot of the new hyperchaotic system (1) in the  $(x_1, x_2)$  plane for  $X_0 = (0.1, 0.1, 0.1, 0.1)$  and  $(a, b, c, d) = (30, 15, 3, 2)$

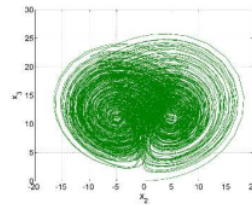

**Figure 2.** 2-D plot of the new hyperchaotic system (1) in the  $(x_2, x_3)$  plane for  $X_0 = (0.1, 0.1, 0.1, 0.1)$  and  $(a, b, c, d) = (30, 15, 3, 2)$

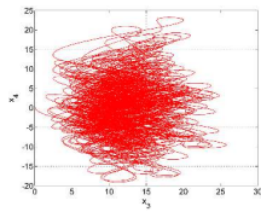

**Figure 3.** 2-D plot of the new hyperchaotic system (1) in the  $(x_3, x_4)$  plane for  $X_0 = (0.1, 0.1, 0.1, 0.1)$  and  $(a, b, c, d) = (30, 15, 3, 2)$

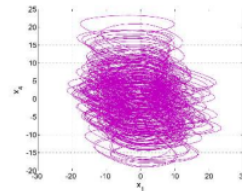
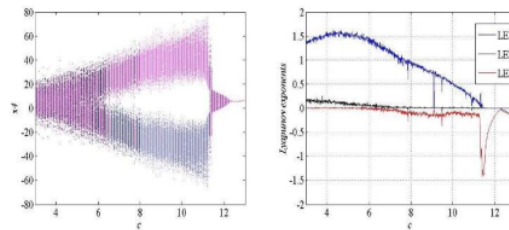

**Figure 4.** 2-D plot of the new hyperchaotic system (1) in the  $(x_1, x_4)$  plane for  $X_0 = (0.1, 0.1, 0.1, 0.1)$  and  $(a, b, c, d) = (30, 15, 3, 2)$

**3. Bifurcation Analysis for the New Hyperchaotic System**

In this section, we describe a detailed bifurcation analysis for the new hyperchaotic system (1) introduced in Section 2. Bifurcation analysis is an important topic for studying chaotic and hyperchaotic systems. In addition, multistability means the coexistence of two or more attractors with the same parameter set but with different initial values. Multistability can lead to very complex behaviors in a dynamical system. Fix  $a = 30, b = 15, d = 2$  and keep  $c$  as the control parameter. When  $c$  is varied in the region of  $[3, 13]$ , the coexisting bifurcation model of the state variable of  $x_4$  and the corresponding Lyapunov exponents (for better clarity, only the three largest Lyapunov exponents are presented, and the missing ones have smaller negative values) with the initial state  $(0.1, 0.1, 0.1, 0.1)$  are plotted in Figure 5 (a) and 5(b), respectively, where the blue orbit starts from the initial state  $(0.1, 0.1, 0.1, 0.1)$  and the magenta orbit starts from the initial state  $(-0.1, -0.1, 0.1, -0.1)$ . From Figure 5(a), we can observe several kinds of coexisting attractors with different initial conditions.

Figure 6 exhibits the coexisting hyperchaotic attractors with  $c = 6.7$  and the coexisting hyperchaotic attractors with  $c = 9, (+, 0, -, -)$  where the blue attractor begins with the initial state  $(0.1, 0.1, 0.1, 0.1)$  and the magenta one begins with the initial state  $(-0.1, -0.1, 0.1, -0.1)$ . Specially, it can be seen that the system starts from a period-1 orbit with the sign of the Lyapunov exponents  $(0, -, -, -)$  in the region of  $[12.25, 13]$  and then evolves into quasi-periodic orbits with the sign of the Lyapunov exponents  $(0, 0, -, -)$  in the region of  $[11.4, 12.25]$  and then goes into chaos with the sign of the Lyapunov exponents in the region of  $[6.8, 11.4]$  and finally develops hyperchaos with the sign of the Lyapunov exponents  $(+, +, 0, -)$  in the region of  $[3, 6.8]$  with the control parameter  $c$  reducing the region of  $[3, 13]$ . The corresponding phase portraits are plotted in Figure 7. From the above analysis, we can conclude that the system indeed displays very complicated dynamics.



**Figure 5.** Bifurcation diagram and Lyapunov exponents of the new hyperchaotic system (1), where we fix  $a = 30, b = 15, d = 2$

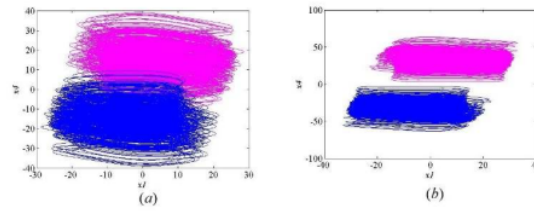

**Figure 6.** For the new hyperchaotic system (1): (a) when  $c = 6.7$ , coexisting hyperchaotic attractors, and (b) when  $c = 9$ , coexisting chaotic attractors

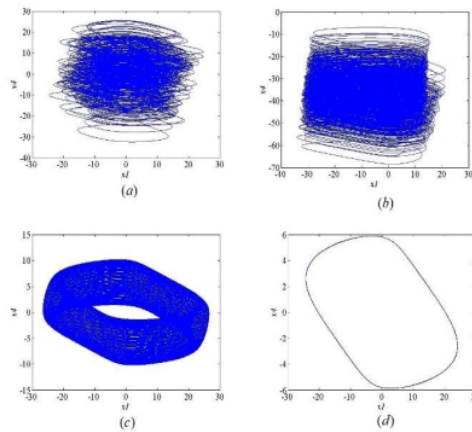

**Figure 7.** For the new hyperchaotic system (1): (a) when  $c = 4$ , hyperchaos, (b) when  $c = 10$ , chaos, (c) when  $c = 12$ , quasi-period, and (d) when  $c = 13$ , period-1 orbits

**4. Circuit Implementation of the New Hyperchaotic System**

In this section, circuit design and implementation of new hyperchaotic system (1) are presented to validate the chaotic behaviour of system (1). The circuit construction of system in (1) has further verified its complex dynamic behaviors by software MultiSIM. Phase portraits obtained using circuit design of system (1) is shown in Figure 5. the circuit realization equation of of new hyperchaotic system (1) is shown in (12):

$$\begin{cases} \dot{x}_1 = \frac{1}{C_1 R_1} x_2 - \frac{1}{C_1 R_2} x_1 + \frac{1}{10 C_1 R_3} x_2 x_3 \\ \dot{x}_2 = \frac{1}{C_2 R_4} x_2 - \frac{1}{10 C_2 R_5} x_1 x_3 + \frac{1}{C_2 R_6} x_4 \\ \dot{x}_3 = -\frac{1}{C_3 R_7} x_3 + \frac{1}{10 C_3 R_8} x_1 x_2 \\ \dot{x}_4 = -\frac{1}{C_4 R_9} x_1 - \frac{1}{C_4 R_{10}} x_2 \end{cases} \tag{12}$$

We choose the system parameters as in the hyperchaotic case, viz.

$$a = 30, \quad b = 15, \quad c = 3, \quad d = 2$$

The values of four capacitors in Figure 8 are taken as  $C_1 = C_2 = C_3 = C_4 = 3.2 \text{ nF}$ .  $R_1 = R_2 = 13.33 \text{ k}\Omega$ ,  $R_3 = R_5 = 40 \text{ k}\Omega$ ,  $R_4 = 26.67 \text{ k}\Omega$ ,  $R_6 = 400 \text{ k}\Omega$ ,  $R_7 = 133.33 \text{ k}\Omega$ ,  $R_9 = R_{10} = 200 \text{ k}\Omega$ ,  $R_{11} = R_{12} = R_{13} = R_{14} = R_{15} = R_{16} = 100 \text{ k}\Omega$ .

The circuit simulation result by MultiSIM is illustrated in Figure 9.

It is seen from Figure 9 that phase portraits obtained using circuit implementation matches with the results obtained using MATLAB simulation.

**5. Conclusions**

A new four-dimensional hyperchaotic system with three quadratic nonlinearities was announced in this paper. The dynamical properties of the new hyperchaotic system are described in terms of phase portraits, Lyapunov exponents, Kaplan-Yorke dimension, dissipativity, etc. Also, a detailed bifurcation analysis of the new hyperchaotic system was carried out with bifurcation diagram and Lyapunov exponents. Multistability and coexisting chaotic as well as hyperchaotic attractors are observed for suitable values of the system parameters. Furthermore, an electronic circuit realization of the new hyperchaotic system was carried out via MultiSIM to confirm the feasibility of the theoretical hyperchaotic model.

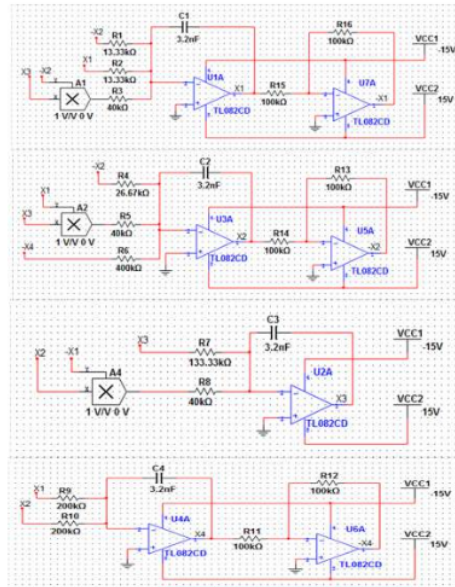

**Figure 8:** Circuit design of the new hyperchaotic system (1)

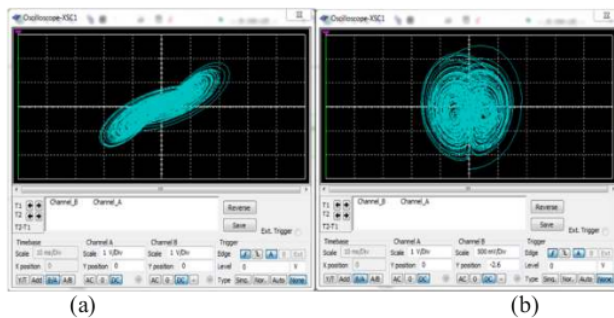

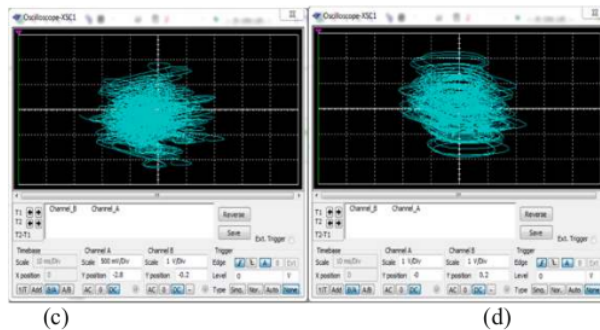

**Figure 9:** Hyperchaotic attractors of system (1) using Multisim circuit simulation: (a) in  $x_1 - x_2$  plane, (b)  $x_2 - x_3$  plane, (c)  $x_3 - x_4$  plane and (d)  $x_1 - x_4$  plane .

## 6. References

- [1] Vaidyanathan S and Volos C 2017 *Advances and Applications in Chaotic Systems* (Berlin: Springer)
- [2] Pham V T, Vaidyanathan S, Volos C and Kapitaniak T 2018 *Nonlinear Dynamical Systems with Self-Excited and Hidden Attractors* (Berlin: Springer)
- [3] Vaidyanathan S, Azar A T, Rajagopal K, Sambas A, Kacar S and Cavusoglu U 2018 *International Journal of Simulation and Process Modelling* **13** 281-96
- [4] Massoud E C, Huisman J, Benincà E, Dietze M C, Bouten W and Vrugt J A 2018 *Ecology letters* **21** 93-103
- [5] Morita Y and Kimura T 2018 *Nonlinear Theory and Its Applications* **9** 95-106
- [6] Tomita K 1982 *Journal of Theoretical Biology* **99** 111-8
- [7] Fei Z, Guan C and Gao H 2018 *IEEE transactions on neural networks and learning systems* **29** 2558-67
- [8] Chaffart D and Ricardez-Sandoval L A 2018 *The Canadian Journal of Chemical Engineering* **96** 113-31
- [9] Vaidyanathan S 2015 *International Journal of Modelling, Identification and Control* **23** 380-92
- [10] Vaidyanathan S, Sambas A, Mamat M and Sanjaya W S M 2017 *Archives of Control Sciences* **27** 541-54
- [11] Vaidyanathan S, Sambas A, Mamat M and Sanjaya W S M 2017 *International Journal of Modelling, Identification and Control* **28** 153-66
- [12] Vaidyanathan S, Sambas A, Kacar S and Çavuşoğlu Ü 2018 *International Journal of Modelling, Identification and Control* **30** 184-96
- [13] Idowu B A, Vaidyanathan S, Sambas A, Olusola O I and Onma O S 2018 *Studies in Systems, Decision and Control* **133** 271-95
- [14] Sambas A, Vaidyanathan S, Mamat M and Mada Sanjaya W S 2018 *Studies in Systems, Decision and Control* **133** 365-373
- [15] Vaidyanathan S, Feki M, Sambas A and Lien C-H 2018 *International Journal of Simulation and Process Modelling* **13** 419-32
- [16] Chen S, Yu S, Lü J, Chen G and He J 2018 *IEEE Transactions on Circuits and Systems for Video Technology* **28** 2359-71
- [17] Rössler O E 1979 *Physical Letters A* **71** 155-7
- [18] Zhu C 2010 *Applied Mathematics and Computation* **216** 3126-32
- [19] Hegazi A S and Matouk A E 2011 *Applied Mathematics Letters* **24** 1938-44
- [20] Yassen M T 2008 *Nonlinear Analysis* **68** 3592-3600
- [21] He J M and Chen F Q 2017 *International Journal of Non-Linear Mechanics* **95** 73-81
- [22] Vaidyanathan S, Pham V T, Volos C and Sambas A 2018 *Studies in Systems, Decision and*

*Control* **133** 345-64

- [23] Zhang S, Zeng Y, Li Z, Wang M, Zhang X and Chang D 2018 *International Journal of Dynamics and Control* **23** 1-12
- [24] Zhang S, Zeng Y, Li Z, Wang M and Xiong L 2018 *Pramana* **90** 63
- [25] Wang L, Zhang S, Zeng Y C and Li Z J 2018 *Electronics Letters* **52** 1008-10
- [26] Zhang S, Zeng Y C, Li Z J, Wang M J and Xiong L 2018 *Chaos* **28** 013113

ORIGINALITY REPORT

---

17%

SIMILARITY INDEX

5%

INTERNET SOURCES

14%

PUBLICATIONS

3%

STUDENT PAPERS

---

MATCH ALL SOURCES (ONLY SELECTED SOURCE PRINTED)

---

1%

★ doaj.org

Internet Source

---

Exclude quotes Off

Exclude matches Off

Exclude bibliography On

GRADEMARK REPORT

---

FINAL GRADE

**/0**

GENERAL COMMENTS

**Instructor**

---

PAGE 1

---

PAGE 2

---

PAGE 3

---

PAGE 4

---

PAGE 5

---

PAGE 6

---

PAGE 7

---

PAGE 8

---

PAGE 9

---